



QWM 1950

UHF Wireless Microphone System

Instruction Manual



CONTENTS

1. Introduction
2. Parts (Receiver)
3. Receiver Display
6. Handheld Operation
8. Bodypack Operation
10. Receiver Operation
12. Technical Specifications

Thank you for purchasing this Q-Audio product, we are sure that it will serve you for many years to come.

To optimise the performance of this product, please read these operating instructions carefully to familiarise yourself with the basic operations of this unit. Please retain them for future reference. This unit has been tested at the factory before being shipped to you.

To prevent or reduce the risk of electrical shock or fire, do not expose the unit to rain or moisture. To prevent a fire hazard, do not expose the unit to any naked flame sources. Unplug this apparatus during lightning storms or if it is unlikely to be used for long periods of time.

When installing the unit, please ensure you leave enough space around the unit for ventilation. Slots and openings in the unit are provided for ventilation to ensure reliable operation of the product and to protect it from overheating.

To prevent fire hazard, the openings should never be blocked or covered.

The unit is mains powered, always handle the power cable by the plug. Never pull out the plug by pulling on the cable. Never touch the power cable when your hands are wet as this could cause an electric shock. Do not tie a knot in the cable. The power cable should be placed such that it is not likely to be stepped on. A damaged power cable can cause a fire or give you an electrical shock. Check the power cord periodically, if you ever find that it is damaged, replace it before using the unit again. Contact your retailer for a replacement.

The voltage of the available power supply differs according to country or region. Be sure that the power supply voltage of the area where this unit is to be used meets the required written on the unit.

The lightning flash symbol inside a triangle is to alert the user to the presence of high voltage within the unit's enclosure that may be of sufficient power to constitute a risk of electrical shock to persons.

Caution: to prevent the risk of electric shock, do not attempt to open the unit. No user-serviceable parts inside. Refer all servicing to qualified service personnel.

The exclamation mark inside a triangle is intended to alert the user to the presence of important operating and maintenance instructions in the literature accompanying the appliance.

Select the installation location of your unit carefully. Avoid placing it in direct sunlight or locations subject to vibration and excessive dust. Do not use the unit where there are extremes in temperature (below 41°F / 5°C or exceeding 95°F / 35°C).

Unpacking and safety Please unpack your new product carefully. Your new product should reach you in perfect condition. Please check that no damage has occurred during transit. If any damage is found, do not operate your unit. Please contact the retailer you purchased it from immediately. If there is any damage to the mains cable do not use the device. Always disconnect the unit from the mains supply when carrying out any cleaning of the unit.

Manufacturer declarations

In compliance with the following requirements: RoHS Directive (2002/95/EU) and WEEE Directive (2002/96/EU), and Battery Directive (2006/66/EU). If this product is ever no longer functional please take it to a recycling plant for environmentally friendly disposal. Any supplied batteries can also be recycled.

CE declaration of conformity

R&TTE Directive (1999/5/EU), EMC Directive (2004/108/EU), Low Voltage Directive (2006/95/EU).

The declarations are available on application from info@q-audio.co.uk

Before putting device into operation, please observe the respective country-specific regulations.

Due to continuous product development, please ensure that you have downloaded the latest instruction manual for this product from the Q-Audio website

Telephone: (+44) (0) 203 598 5164 • Email: info@q-audio.co.uk • Web: www.q-audio.co.uk

If this product is ever no longer functional please take it to a recycling plant for environmentally friendly disposal.

Due to continuous product development, specifications and appearance are subject to change. © Copyright Q-Audio. E&OE.



3. Receiver

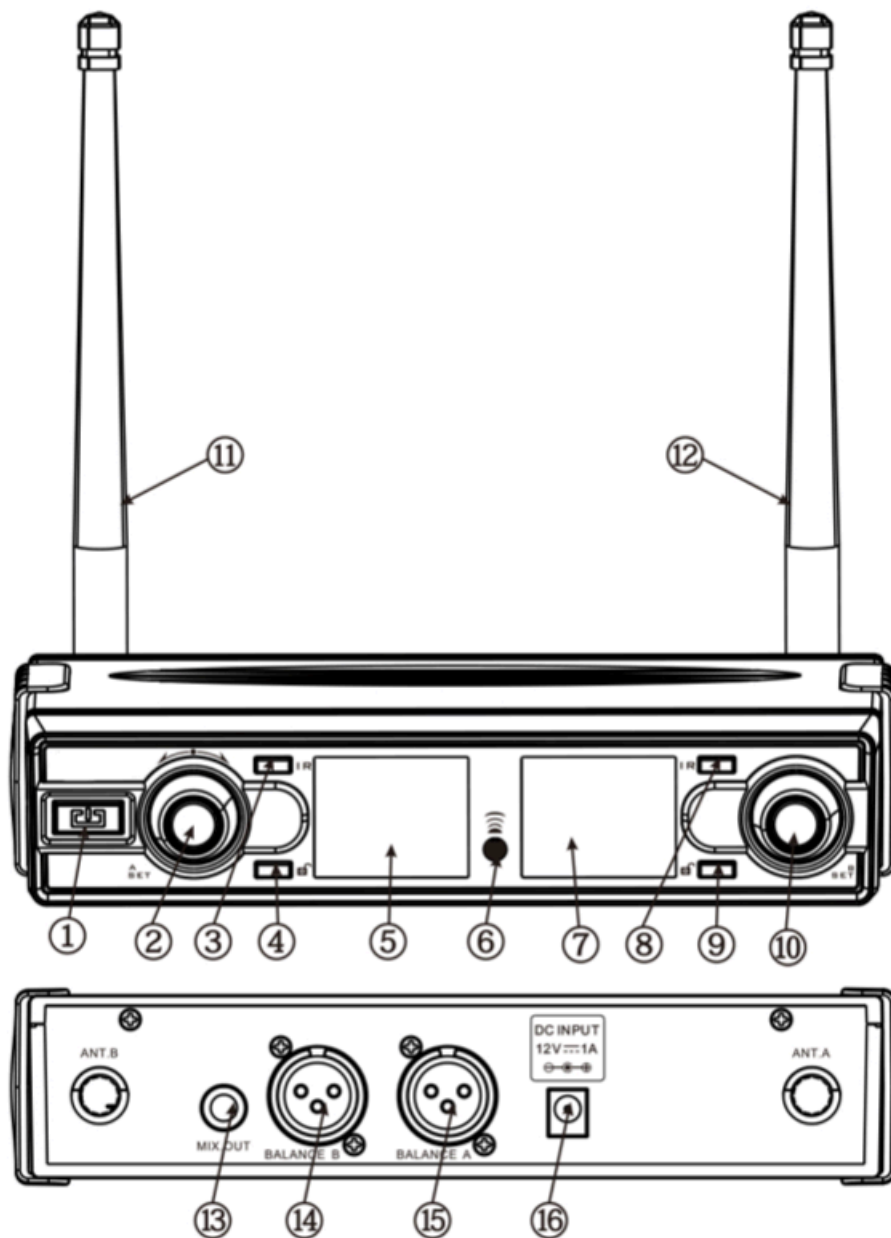

1. Power Switch

2. Setup A

3. IR Button A

4. Unlock A

5. Display A

6. IR Window

7. Display B

8. IR Button B

9. Unlock B

10. Setup B

11. Antenna A

12. Antenna B

13. 1.4" Jack Mixed Output

14. Balanced Output A

15. Balanced Output B

16. DC Power Input

4. RECEIVER DISPLAY

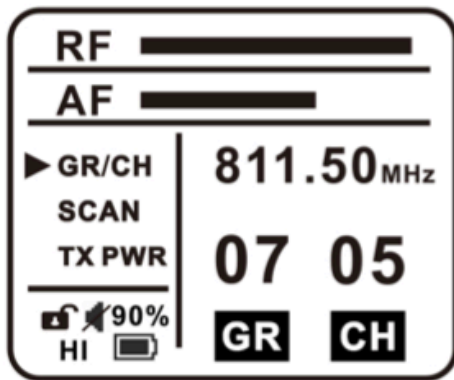

RF: Indicates wireless signal strength, the longer the coloured bar length, the stronger the signal.

AF: Indicates audio level, the longer the coloured bar length, the higher the audio signal.

GR/CH

GR: Group - A preset group of frequencies

CH: Channel - A preset frequency inside a group, select group/channel by pressing set (2, 10) and turning the knob to change the channel number.

SCAN
UP
DOWN

Auto Scan - Automatically scan up or down to search for available frequencies until the desired frequency is reached.

TX PWR
HI
LO

TX PWR - Hi or Lo, Indicates the transmitter power, High or Low Transmit Power, High will transmit further but consume more power thus High will decrease battery life.



Lock Status - Locked means buttons on the receiver are inactive



Mute indicates the receiver is in MUTE status.

90%

Indicates the current volume output of the receiver, the range range is adjustable from 0% to 100% in steps.



The battery icon indicates the transmitter's battery status.



Adjust the receiver's volume by turning the knobs (2, 10) when the unit has powered on and is not in any menu.

Display function operation

When the receiver is on, hold the unlock button (4, 9) for a few seconds to unlock the system before changing any settings.

Once unlocked, the following settings can be set and adjusted.

- Channel setting model

select menu icons

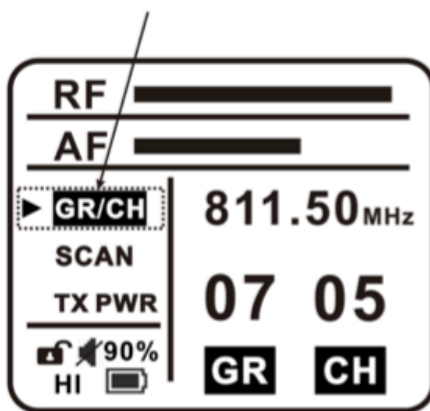

numbers change

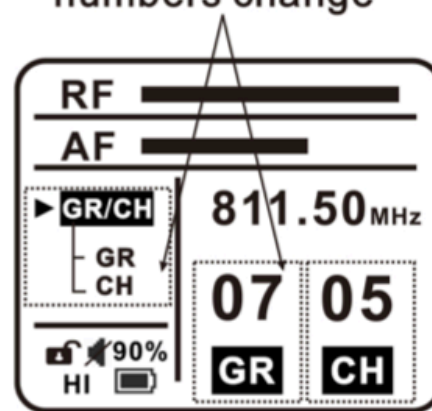

1. Press the setup knob (2, 10) to enter the setup menu, the first option GR/CH will be highlighted and flashing on the display, press the setup knob to enter this menu setting.
2. Twist the setup knob left or right to select the appropriate channel required.
3. Press the setup knob to confirm your selection.
4. Use the IR Sync function to remotely set the transmitter to the chosen channel / frequency.

- **Frequency Scan Mode**

Select menu item

Spectrum analysis report of the wireless environment



- 1) Press the setup knob (2, 10) and twist the knob to navigate to the SCAN function.
- 2) Press the setup knob again to select the SCAN function.
- 3) Select up or down and press the knob again to search for available frequencies until the desired frequency is found.

This function makes it convenient for users to find available frequencies quickly.

- **Volume Adjustment Mode**

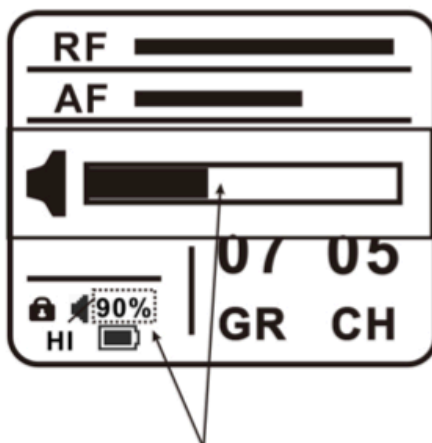

Voice Volume

- 1) Ensure the receiver is not in a menu, if it is please exit back to the main screen.
- 2) Twist the setup control knob (2, 10) to directly adjust the volume, a bar will appear showing you a level bar. Each channel can be adjusted individually by using the appropriate setup control knob for that channel.

5. HANDHELD MICROPHONE OPERATION

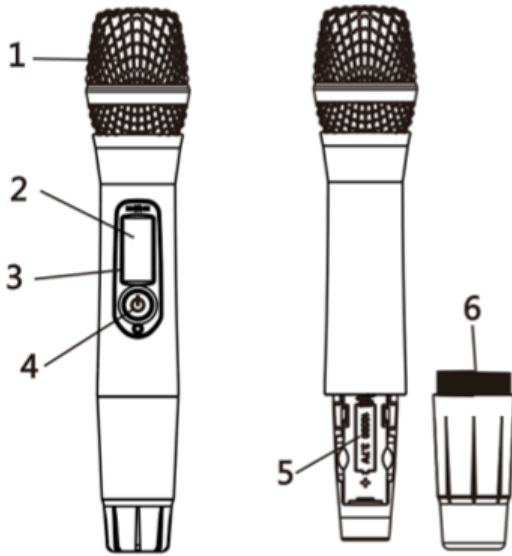

1. Microphone Capsule & Grille
2. LCD Display
3. Sync Window
4. On/Off/Mute Switch
5. Battery Compartment with internal indicator showing correct polarity
6. Battery Compartment Cover

► HANDHELD MICROPHONE LCD FUNCTION

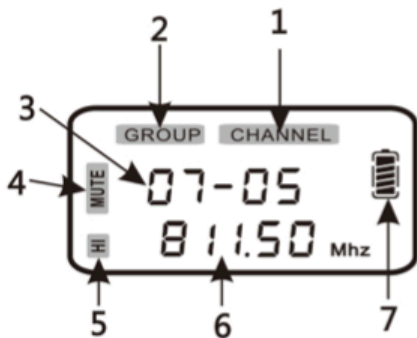

CHANNEL

Indicates channel shown below

GROUP

Indicates group shown below

07-05

Indicates current group + channel

MUTE

Indicates mute status

HI

Indicates Hi/Lo transmitter power

811.50 Mhz

Indicates current frequency



Indicates battery status, indicates low power when flashing



Powering Off: With the microphone on, hold the On/Off button until the screen shows OFF.

The microphone will then automatically power off and the power button can be released.

- Remove the battery cover and insert 2x 1.5V AA batteries paying attention to the polarity shown inside the battery compartment.
- Hold down the power button, If the LCD screen does not light, check if the battery polarities are correct or if the batteries are low. If the battery indicator flashes on the LCD, please change the batteries for new ones.
- The handheld can only work on the same frequency, group + channel as the receiver, it should only be synced to one receiver channel.
- The handheld will remember its last settings when switched off, there should be no need to re-sync the transmitter and receiver again unless you wish to change the group or channel.

HANDHELD MICROPHONE USING TECHNIQUE

Do not hold the microphone by the grille



Do not cover the antenna positions of the microphone

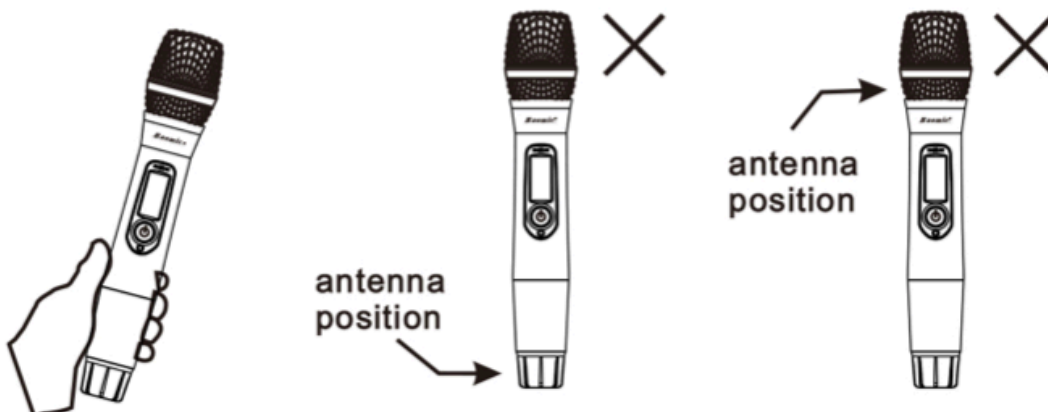

3. Do not place the two microphone transmitters together.



4. Ensure that the distance between the microphone grille and the mouth of the user is less than 15cm.

5. Avoid pointing the grille of the microphone towards a speaker or output device.

6. BODYPACK OPERATION

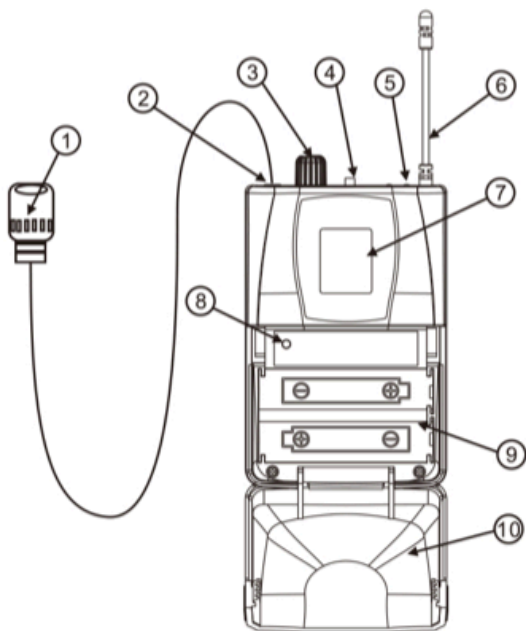

1. Microphone
2. Input Socket (4 pin mini XLR)
3. Adjustable volume knob
4. On/Mute/Off Switch
5. Power Indicator
6. Antenna
7. LCD Display
8. IR Setting Switch
9. Battery Compartment (2x 1.5V AA Batteries)
With Polarity Indicators
10. Battery Compartment Cover

► BODYPACK LCD FUNCTION

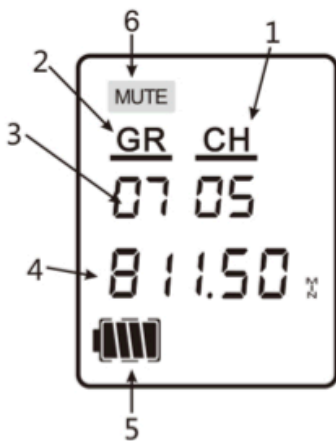

CH	Indicates the channel number set below
GR	Indicates the group number set below
07 05	Indicates the current group and channel that the transmitter is set to (e.g. Group 7, Channel 5)
811.50 MHz	Indicates the current wireless frequency
	Indicates the current battery status, the battery is low when this icon flashes.
	Indicates the current mute status of the bodypack transmitter, when shown the bodypack is in the mute state.

Remove the battery cover and insert 2x 1.5V AA batteries paying attention to the polarity shown inside the battery compartment.

Set the on switch to the “ON” position. If the LCD screen does not light, check if the battery polarities are correct or if the batteries are low. If the battery indicator flashes on the LCD, please change the batteries for new ones.

The bodypack can only work on the same frequency, group + channel as the receiver, it should only be synced to one receiver channel.

The bodypack will remember its last settings when switched off, there should be no need to re-sync the transmitter and receiver again unless you wish to change the group or channel.

Please Note that the IR Sync function is only active for 30 seconds and begins as soon as you press the IR Sync button on the receiver.

7. RECEIVER OPERATION

1. Adjust the antenna (11), (12) ensuring they are perpendicular to the receiver.
2. Connect the power :
 - Connect the power cable to the DC socket on the receiver (16), make sure the adapter's voltage and current is suitable for the receiver.
3. Connect the audio cable:
 - Mix Output - Connect a 1/4" jack cable to the mix out socket (13) connect the opposite end of the cable to your audio device.
 - Balanced Outputs - Connect an XLR cable to the balanced socket(s) (14, 15) and connect the opposite end of the cable to your audio device.
4. Turn on the receiver:
 - Press the power button (1) and the display will light to indicate the unit is powered and ready for use.
 - It is always a good idea to set the volume controls (2, 10) to the minimum setting before powering on. Adjust the volume when the unit is powered.
5. Set the receiver up by pressing the setup knob (2, 10) and adjust the settings by rotating the knob left and right, press the knob to confirm your selection.
6. To use the IR Sync feature, please see the image on the next page. To start the IR Sync feature press and hold the IR Button (3 or 8) depending on which channel you would like to sync. After a few seconds, release the button and the receiver will automatically start to send the IR signal for the transmitter to pickup. Follow the guidelines on the next page to ensure the transmitter picks up the signal correctly.

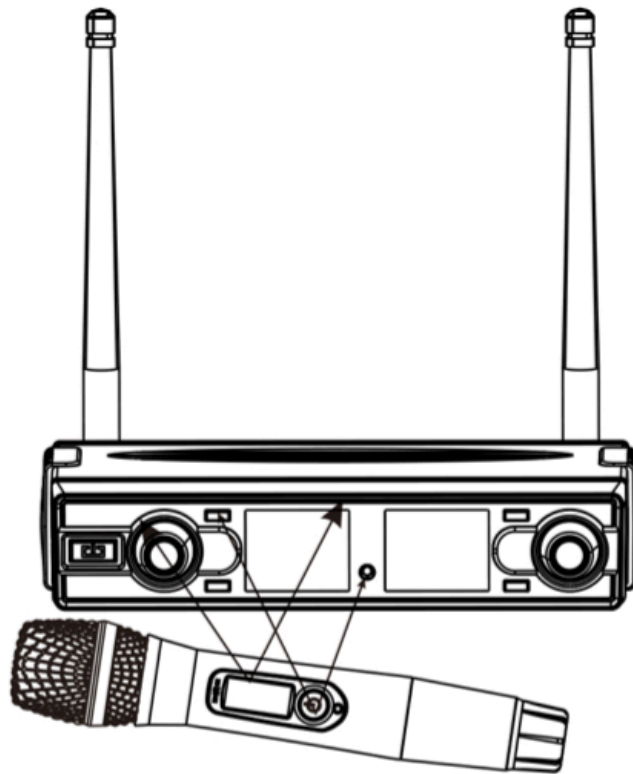

With both the transmitter and receiver powered on, hold down the IR button of the channel you wish to sync (A or B) on the receiver, release the button after a few seconds. Face the transmitter's IR window to the receiver's IR Window and ensure they are close together.

Once paired, the receiver will stop sync mode and will show RF on the display.

► Correct Receiver Placement

Please ensure that the receiver is more than 1 meter away from walls and floors for best RF performance.

Ensure the antennas aren't obstructed or covered.

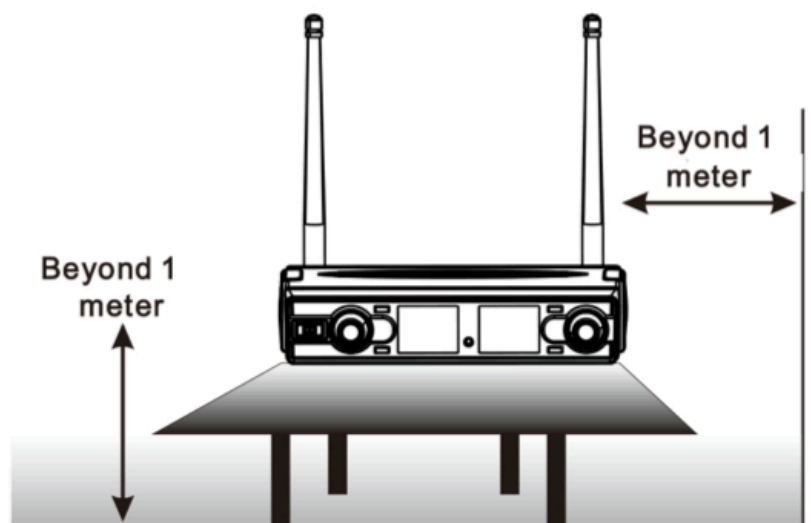

8. TECHNICAL SPECIFICATIONS

Receiver:

Frequency: 863 – 865MHz or 606 – 614 MHz (See barcode)

Bandwidth: 2MHz or 8MHz (Frequency Dependent)

Dynamic Range: 90dB

Distortion: <0.5%

Signal/Noise Ratio: 90dB

Frequency Response: 30Hz – 20kHz \pm 2dB

Signal/Noise Ratio: 90dB

Receiving Sensitivity: -95dBm

Power Supply: DC 12V 1A

Audio Output: 1x Mixed Unbalanced 6.3mm Jack, 2x Balanced XLR

Display: Colour TFT

Transmitters:

Frequency Switching: IR Sync

Harmonic Radiation: <-50dBc

Output Power: Up to 30mW

Batteries Required: 2x1.5V AA batteries

Battery life: >6h

Frequency Charts:

Frequency charts are available on the Q-Audio website (www.q-audio.co.uk) Please navigate to the product page using the main menu and the frequency charts will be available for you to download on the specific product's page.

Box Contents

1x QWM 1950 Receiver

2x Transmitters

1x 1/4" Jack Cable

1x Power Adapter

2x 1.5V AA Batteries

1x Manual